

B (2:3)

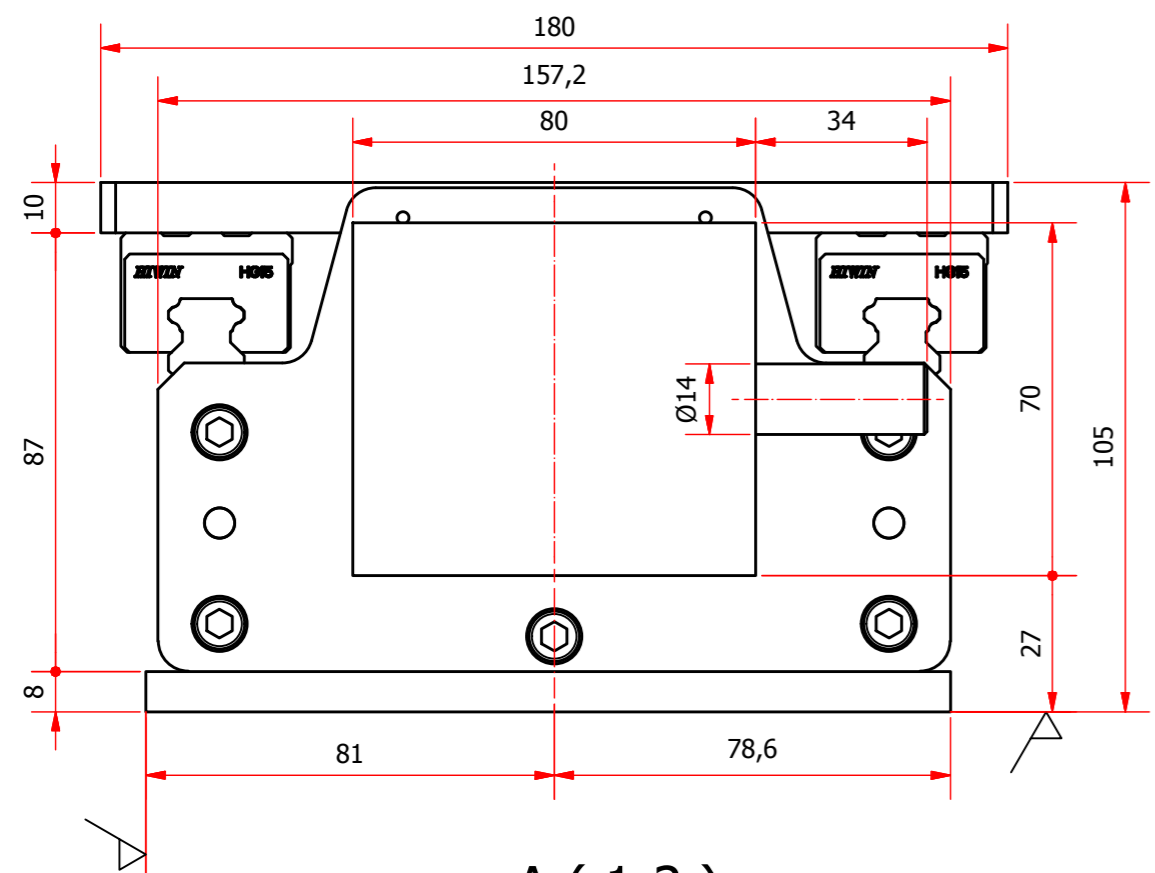

A (1:2)

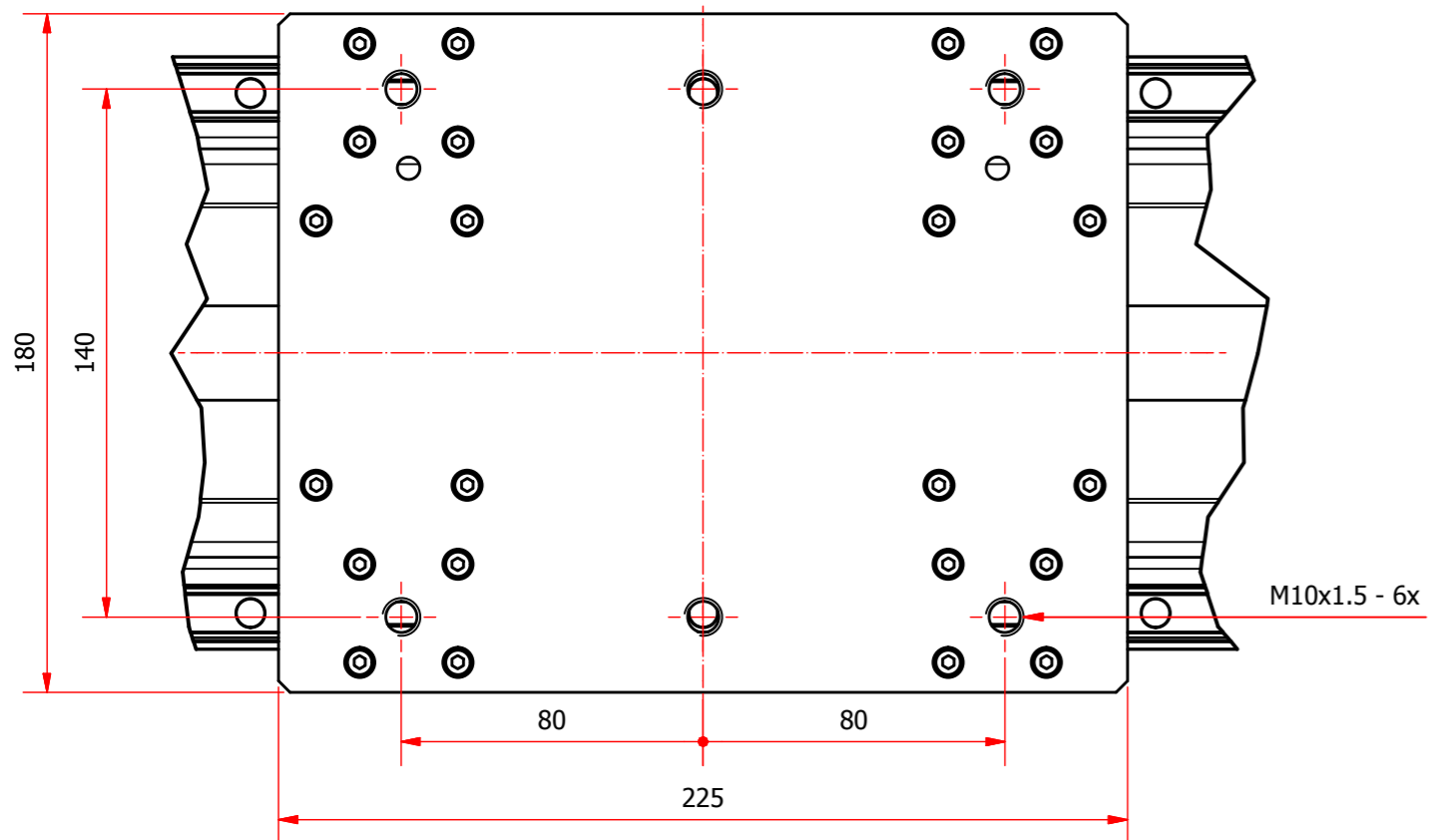

C-C (1:2)

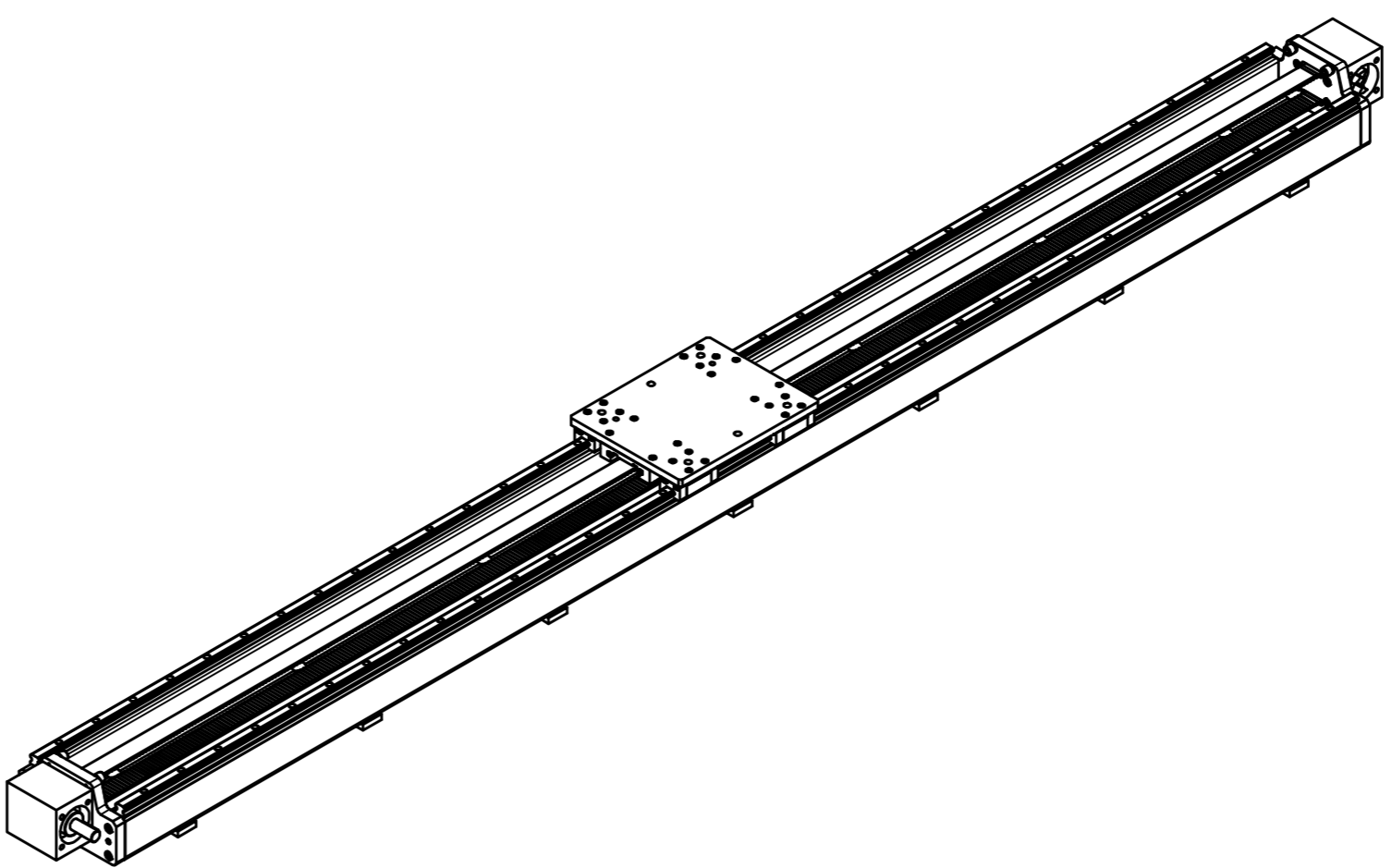
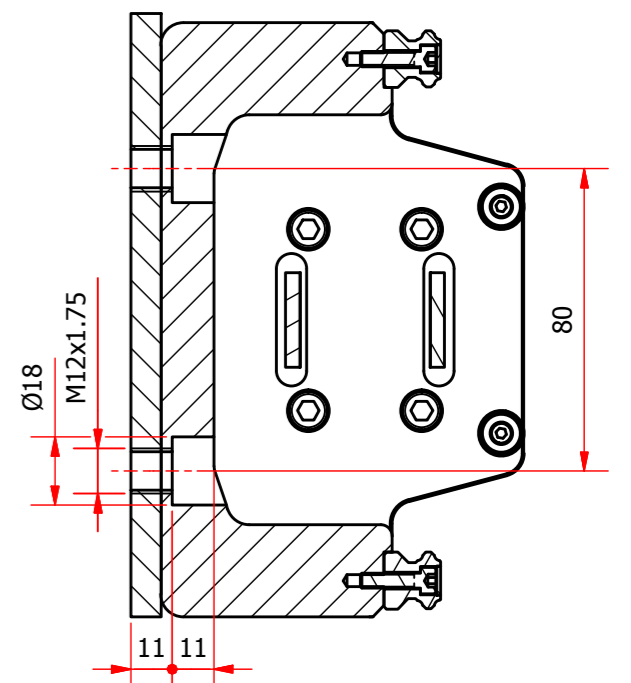

✓	▽	∇	GENERAL TOLERANCES		ISO 2768-mk	ASSEMBLY No.	QUANTITY
Specified roughness Ra	DIMENSION	ANGLE	0,2	0,5	WELD DIN 8570-BF	TITLE	
Ra	UNIT	MATERIAL :	3,20	mm		ASSEMBLY	
SCALE	FORM	THREATMENT :	1:4	A2		DRWG. No.	
		PROJ : KK-BD	CLIENT : VANSICHEN		<b>KK-BD-180-15-5M25-2000</b>		
		REV. No. : 0	KH	DAT.: 18/01/2013	PAG. 1 / 1	<b>VANSICHEN LINEAIRTECHNIEK</b>	